



**Ducted Self-Contained  
Wine Cellar Cooling Systems  
Installation, Operation and Maintenance Manual  
60Hz Models: DP25, DP50, DP88, DP200**



**Manufactured by**



AIR INNOVATIONS

Syracuse, NY

[wineguardian.com](http://wineguardian.com)

[airinnovations.com](http://airinnovations.com)

Wine Guardian reserves the right, without notice, to make changes to this document at its sole discretion.

Please visit our web site for the most current version of the Wine Guardian manual and other literature.

Wine Guardian is a registered trademark (2,972,262) of Air Innovations, Inc.

Edition 10/2025 (Original Instructions)

© Air Innovations 2021

Part No. 15H0327-00

REV: B

# Table of Contents

<b>Safety</b> .....	3
<b>Lockout/Tagout Procedure</b> .....	4
<b>Safety Warnings</b> .....	4
<b>Receiving, Inspecting and Unpacking</b> .....	4
<b>Directory of terms</b> .....	5
<b>General Overview</b> .....	6
<b>Accessories/Options</b> .....	9
<b>Component Overview</b> .....	9
<b>Terminal Strip</b> .....	12
<b>Wiring Diagrams</b> .....	13
<b>Dimensions/Specifications</b> .....	19
<b>Specifications</b> .....	21
<b>Installation</b> .....	22
<b>Pre-Installation</b> .....	22
<b>Pre-Installation Planning</b> .....	22
<b>Reducing Noise Generation</b> .....	23
<b>Ductwork</b> .....	24
<b>Duct Collar and Panel Adjustment</b> .....	25
<b>Drain Line</b> .....	26
<b>Wiring to Power</b> .....	26
<b>Start-Up</b> .....	28
<b>Maintenance</b> .....	29
<b>Flushing the Water Regulating Valve – Water-Cooled Only</b> .....	30
<b>Cleaning the Humidifier (Optional)</b> .....	30
<b>Maintenance Schedule</b> .....	30
<b>Monthly</b> .....	30
<b>Yearly</b> .....	30
<b>Troubleshooting</b> .....	31
<b>Resetting the High-Pressure Switch</b> .....	31
<b>Contact and Warranty</b> .....	33
<b>Contact Information</b> .....	34
<b>Warranty</b> .....	34

## **Safety**

The safety messages contained in this manual are highlighted in red bolded and for quick identification. A Danger message indicates an imminently hazardous situation which, if not avoided, can result in death or serious injury. Messages identified by the word DANGER are used sparingly and only for those situations presenting the most serious hazards. The following is a typical example of a Danger message as it could appear in the manual.



### **HIGH VOLTAGE - RISK OF SERIOUS INJURY OR DEATH**

**High voltages are present in the cabinets.**

**Before opening panels turn off all power.**

**Use the Lockout/Tagout procedure.**

The equipment covered by this manual is designed for safe and reliable operation when installed and operated within its designed specifications. To avoid personal injury or damage to equipment or property when installing or operating this equipment, it is essential that qualified, experienced personnel perform these functions, using good judgment and safe practices. See the following cautionary statements. Installation and maintenance of this equipment is to be performed only by qualified personnel who are familiar with local codes and regulations and are experienced with this type of equipment.

Exposure to safety hazards is limited to maintenance personnel working in and around the unit. When performing maintenance, always use the Lockout/Tagout procedure, which is described in this chapter. Observe the maintenance safety guidelines in the Wine Guardian Manual.

**Electrical Hazards** - Working on the equipment may involve exposure to dangerously high voltage. Make sure you are aware of the level of electrical hazard when working on the system. Observe all electrical warning labels on the unit. There are no electrical safety lockouts installed within the unit. The power cord attached to the control box must be disconnected from the power sources prior to working on any part of the electrical system.

**Hot Parts Hazards Electric** - Resistance heating elements must be disconnected prior to servicing. Electric heaters may start automatically, disconnect all power and control circuits prior to servicing the unit to avoid burns.

**Moving Parts Hazards** - The motor and blower must be disconnected prior to opening access panels. The motor can start automatically. Disconnect all power and control circuits prior to servicing to avoid serious injuries or possible dismemberment. Be sure to use the Lockout/Tagout procedure when working on these units.

## **Lockout/Tagout Procedure**

1. Turn off the power switch (indicator light should be off).
2. Unplug the unit from the electrical outlet and cover the outlet to prevent accidentally plugging in the unit.

## **Safety Warnings**

- Never reach into a unit while the fan is running.
- Disconnect all power sources before working on the unit.
- Check weights to be sure the rigging equipment can support and move the Wine Guardian unit safely. **Note:** any specific rigging and installation instructions located in the [Installation section](#) of the Wine Guardian Manual.
- Do not remove access panels until fan impellers have completely stopped. Pressure developed by moving impellers can cause excessive force against the access panels.
- Never pressurize equipment above specified test pressure (~300 psi).
- Always ground the outlet to provide adequate protection against voltage surges and built-up static charges.
- Refer all servicing to qualified service personnel. Servicing is required when the unit has been damaged in any way.
- Do not use extension cords.
- Do not modify the equipment; it may cause damage to the equipment and will void the warranty.

## **Receiving, Inspecting and Unpacking**

When receiving the unit, ensure the unit is undamaged and includes all ordered accessories.

**Note:** Wine Guardian units are factory assembled and tested prior to shipment. Wine Guardian units are shipped in individual corrugated boxes.

- ✓ Lift at the designated handhold locations only or fully support from underneath. A shipment may include one or more boxes containing accessories.
- ✓ Before opening the container, inspect the packing crates or boxes for obvious signs of damage or mishandling.
- ✓ Write any discrepancy or visual damage on the bill of lading before signing.
- ✓ Inspect all equipment for any sign of damage caused during transit.
- ✓ Report all visual or concealed damage to the carrier and file a claim immediately.
- ✓ Thoroughly inspect the contents for any visible damage or loose parts.

### **IMPORTANT**

If this procedure is not followed, the shipping company may reject the claim and the consignee may suffer the loss. Do not return the shipment to the factory.

Review the Packing Slip to verify the following:

- ✓ Model #
- ✓ Factory Installed Options
- ✓ Unit Accessories

If any items listed on the packing slip do not match your order information, contact the place of purchase immediately.

Check the unit for these items:

- ✓ An Electrical Power Cord connected to unit
- ✓ 24 volt terminal strip for connection to 24 volt thermostats
- ✓ 7' of Clear Plastic Drain Hose
- ✓ Quick Start Guide

## **Directory of terms**

- **Ambient Air** – The surrounding area outside the cellar such as a room, basement, garage or outdoors.
- **CFM** – Cubic feet per minute. A unit of measurement for the amount of air handled by the fan.
- **Condensate / Condensation** – The water formed out of the air when it is cooled below a certain temperature (called dew point). Often referred to as “sweating” on pipes and cold surfaces. This water collects at the bottom of the evaporator or cooling coil and drains out of the unit through the drain line.
- **Condenser (Heat Rejection) Section / Coil** – The Condenser Section uses the compressor, condenser coil and fan to remove heat from the refrigerant to the ambient air outside the wine cellar. The word condenser refers to the condensation of the refrigerant from gas to liquid phase.
- **CE** – Certificate of European conformity
- **CSA/ETL** – Canadian Standard Association/Electric Testing Laboratory
- **Exhaust Air** – The air leaving the evaporator or condenser section of the Wine Guardian unit.
- **Evaporator (Cooling) Section / Coil** – The Evaporator Section uses the cooling coil and the fan to remove heat from the air inside the wine cellar to the refrigerant, cooling the air and condensing moisture out of the air. The word evaporator refers to the evaporation of the refrigerant from liquid to gas phase in the coil. The Evaporator Section is connected to or inside the wine cellar.
- **Flexible Duct** – Round ducts with steel reinforced plastic liners, a layer of insulation and an outer plastic layer used to convey the air from the unit to the cellar or ambient space.
- **Grille or Diffuser** – Inlet or outlet plates to direct the airflow or protect the inside of the unit.
- **Heat Gain / Loss** – The amount of cooling or heating expressed in watts transferred between the wine cellar and the ambient space. The Wine Guardian must offset this load.

- **Inlet Air** – The air entering the evaporator and condenser sections of the Wine Guardian unit.
- **I.D.** – Inside diameter
- **NEC** – National Electrical Code
- **O.D.** – Outside diameter
- **Psig Pounds** – Force per square inch gauge
- **NEC** – National Electrical Code
- **Recovery** – The amount of cooling the unit does to return the cellar to its set point temperature after some new load is introduced, such as people or new cases of warm wine entering the cellar.
- **Return Air** - The air leaving the cellar and returning to the inlet of the evaporator coil.
- **SP** – Static pressure. Unit of measurement (inches of water column) of the pressure of the air handled by the fan.
- **Set Point** – The desired temperature or humidity set on the thermostat or humidistat.
- **Supply Air** - The air entering the cellar from the discharge of the evaporator coil.

## **General Overview**

The Wine Guardian cooling unit is a professional grade, American manufactured, self-contained climate control unit designed specifically for the storage of wine at cellar temperatures. It is designed for easy installation and operation. Wine Guardian uses digital electronic controls and R-134a refrigerant. The entire unit is tested at the factory and shipped as a single package. All components are of a high quality, standard commercial grade. The entire unit is approved by ETL according to UL 1995 and CSA safety standards. All wiring complies with NEC. Each unit is furnished with a sealed, UL-approved power cord and plug.

The Wine Guardian wine cellar cooling systems are completely self-contained and includes either an integral air cooled or water-cooled condenser. The units are functionally divided into two sections, the evaporator (or cooling section) and the condenser (or heat rejection section). Each section contains a coil to add or remove heat and a fan to move the air through the coil and into or out of the cellar or adjacent space. The Wine Guardian cooling systems are designed to be used as a remotely mounted unit with external ductwork connections.

Air first passes through the cooling coil and is cooled by the refrigerant inside the coil. This causes any excess humidity in the air to condense and be captured in the drain pan and piped outside the unit. Air then enters the fan where it is pressurized and discharged out of the unit. Optional heating coils are located between the cooling coil and the fan. These coils heat the air to prevent low temperatures in the cellar. The thermostat, located in the cellar, turns on the cooling (or optional heating) as needed to maintain its setpoint. It does not allow the cooling and heating to be on at the same time.

The compressor and condenser sections are activated whenever the unit is cooling. The condenser fan draws air from the surrounding or ambient space either directly or

through a duct. The air is first drawn through a filter to remove any airborne dust particles to keep the coil clean. The air flows through the condenser coil where it absorbs heat from the refrigerant in the coil. The air is then discharged out of the unit by the condenser fan. The air exhaust from the condenser fan on air-cooled units is hot and will be 25 to 35 ° F (15 – 18 ° C) above the entering temperature. This may cause overheating problems in the summer months, especially with high humidity. Exhaust the hot air to the outside or to a space that is a minimum of 3x larger than the wine room. In cold weather, this heated air can help to heat the surrounding space.

The safe operating range of the condenser inlet air temperature is 45°F(7.2°C) to 95°F(35°C). If the air temperature entering the unit is above 95°F(35°F) you risk tripping the high-pressure switch.

The water-cooled Wine Guardian system requires cooling water to be piped to the unit for proper operation. The cooling water absorbs the refrigerant heat through the unit's water-cooled condenser coil. Warm water is then directed out of the unit back to the cooling water system. We do not recommend using a water-cooled system if you are using a city water supply.

The safe operating range of the condenser inlet water temperature is 45°F(7.2°C) to 85°F(29.4°C). If the water temperature entering the unit is above 85°F(35°F) you risk tripping the high-pressure switch.

Each Ducted Self-Contained Wine Guardian system Contains:

- ✓ A thermal expansion valve to control the flow of refrigerant into the evaporator coil
- ✓ A Filter Drier
- ✓ A manual reset high pressure switch to protect the system from high pressures
- ✓ The unit uses only R-134a refrigerant
- ✓ A built-in condensate drain trap. (**Do not install an external trap**)

The Wine Guardian 60Hz models meet or exceed their rated capacities for total BTU/H and CFM at design cellar conditions and external static pressures. The Wine Guardian 50Hz models meet or exceed their rated capacities for total watts and cubic liters per second at design cellar conditions and external static pressures. Both the evaporator and condenser fans are capable of rated CFM against the external static pressure imposed by recommended ductwork. Both fans are motorized impeller plug fans, statically and dynamically balanced, and use permanently lubricated, direct drive motors that require no maintenance.

All exterior framing of the Wine Guardian is powder coated aluminum to prevent rust and corrosion. All evaporator coils are aluminum tubes and aluminum fins with a protective anti-corrosion coating. The unit uses an external drain to remove excess moisture and not reintroduce it into the cellar or ambient space. Removable, multiple access doors are provided to facilitate cleaning and maintenance, duct connections, and access to components and wiring. The condenser coils have pre-filters on the inlet to prevent dust and dirt from fouling the coils, thereby reducing capacity. Each unit has at least three discharge outlets on both the evaporator and the condenser coils to

facilitate custom installations. Water-cooled units have copper straight tube connections for both cooling water inlet and outlet.

Compressors are rotary, self-lubricating, permanently sealed, hermetic reciprocating type compressors, with internal overload protection and capacitor start with a minimum of one-year manufacturer's warranty and an optional five-year warranty. Compressors are mounted on rubber-in-shear isolators to reduce noise and vibration. Electric power is supplied by a single, factory-furnished cord and plug. All external controls are digital and proprietary to Wine Guardian products. Only the approved communication cable and Wine Guardian controllers are suitable for proper system operation.

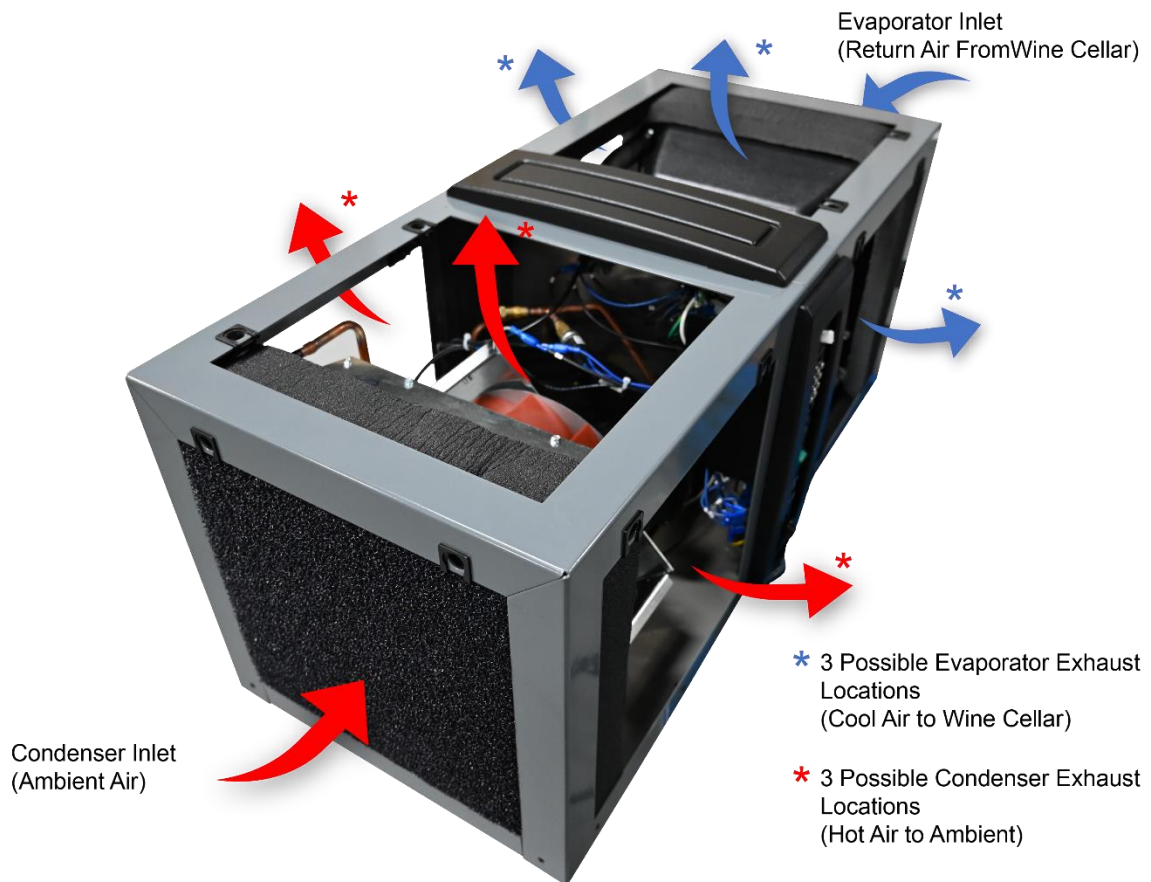

## **Accessories/Options**

### **Electric Heat**

The electric heating option is factory installed and includes primary and secondary over-temperature protection devices per UL and NEC.

### **Humidifier and Humidistat**

Another popular option for the Wine Guardian ducted self-contained unit is a humidifier. The humidifier is available as a freestanding unit powered by the Wine Guardian system with its own power cord and humidistat or as an integrated unit, which bolts to the side of any Wine Guardian ducted system. The Wine Guardian humidifier requires a water supply and drain for operation. Please refer to the Humidifier Manual for Installation Instructions.

### **Duct Collar Kits**

Ducting for the Wine Guardian is sold in kits by size for each unit. Each kit contains two adapter collars, one 25' (7.3 meters) length of round flexible duct and two straps. The number of duct kits needed depends on the layout. The size of the kit depends on the model Wine Guardian selected. Follow installation instructions carefully. Poorly or incorrectly installed ducts can degrade the performance of your unit dramatically.

### **Extended Compressor Warranty**

The Wine Guardian uses only the best commercially available compressors on the market. However, since the compressor is the single most expensive component in the unit, it is recommended that you purchase the extended warranty option.

## **Component Overview**

**Cabinet** – The cabinet (outer housing) is constructed of aluminum with a powder-coated finish for corrosion protection.

**Condensing Section** – Ambient air is circulated through the condenser section by a direct drive, permanently lubricated, motorized impeller blower. This section also contains the compressor and the electrical controls. If the water-cooled option is purchased, a heat exchanger is used in place of the condenser coil and blower.

**Evaporator Section** – Cellar air is circulated through the evaporator section by another blower, similar to the condensing section. The large evaporator-coil face area eliminates condensate carry-over, reduces air pressure drop and optimizes heat transfer. A drain pan is located directly below the coil to capture condensate and is fabricated from aluminum to prevent rust and corrosion. The electric heating coil, if ordered, is factory installed between the evaporator coil and the blower and is complete with contactors and limit controls.

Electrical Controls – Most of the electrical components and controls are in a separate area accessible on the side of the unit. All wiring is in accordance with the NEC. Wires are numbered and color coded to match the wiring diagrams.

Filters – A nominal 1-inch-thick (25-mm-thick) filter is provided on the condenser inlet to protect the coils from dust and dirt. This filter is washable and reusable.

Internal Drain Trap - Water condensate from the evaporator coil fills the trap and forms a seal to prevent air from being drawn back through the drain tube. This allows the drain pan to drain freely. No external trap is required.

Supply/Return Duct Collar – Four duct collars are provided with the unit – two for the evaporator section and another two for the condenser section. Every duct collar is interchangeable with the access doors, allowing you to control and direct the airflow. Each single-direction duct collar is made of composite material. These duct collars can be removed via the two quarter-turn screws.

Removable Panels – Insulated, removable, composite-material panels are provided on both the evaporator and condenser of the unit. These panels can be removed via the two quarter-turn screws.

Fig. 1

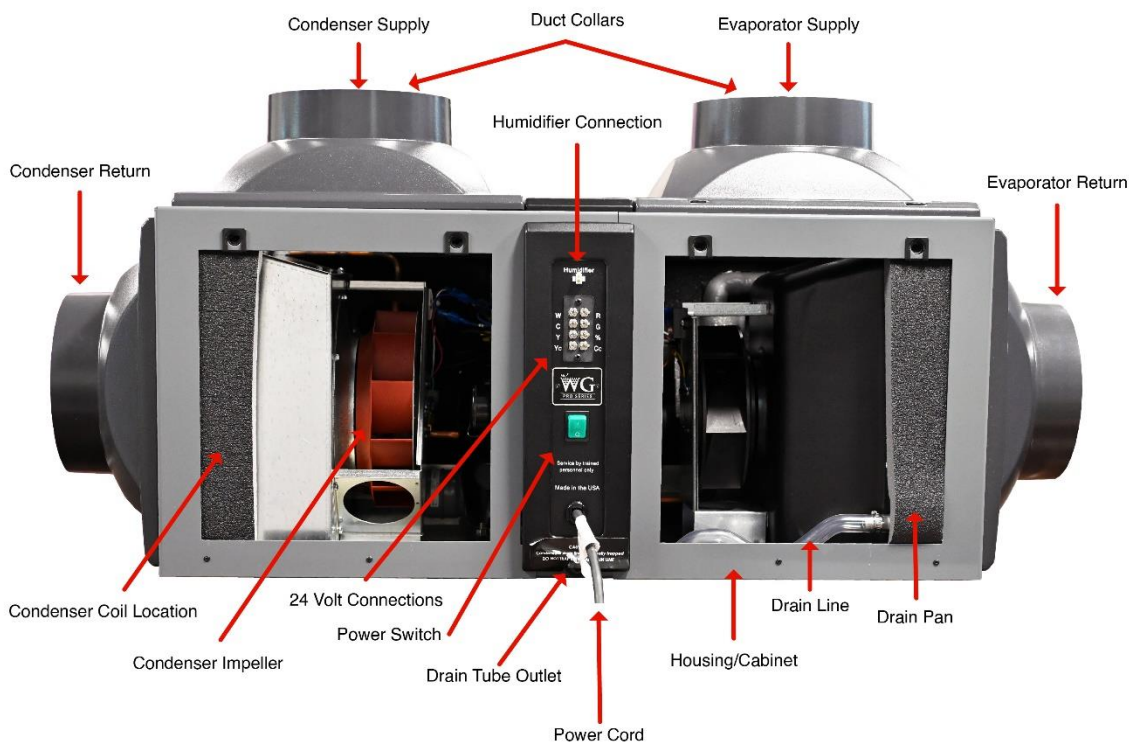

Fig. 2

### Overview Illustration - Vapor Compression System

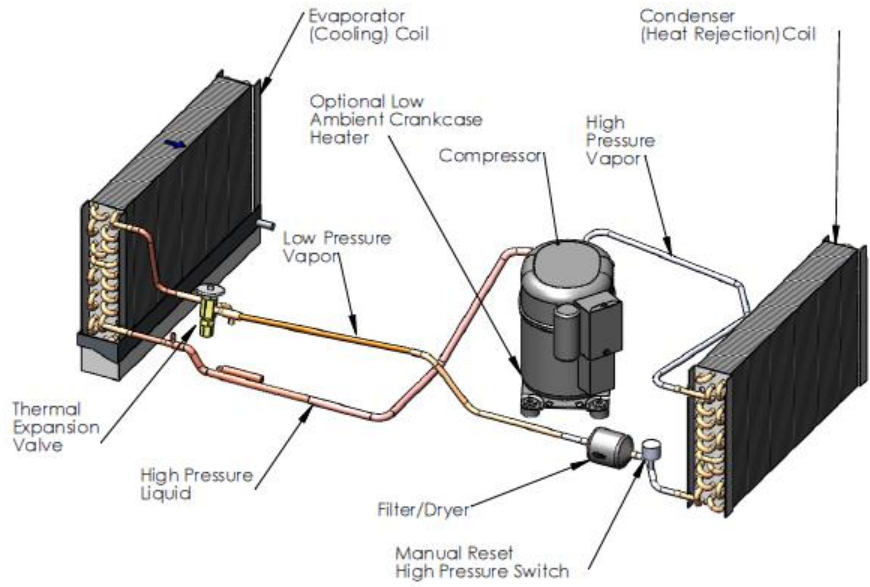

Fig. 3

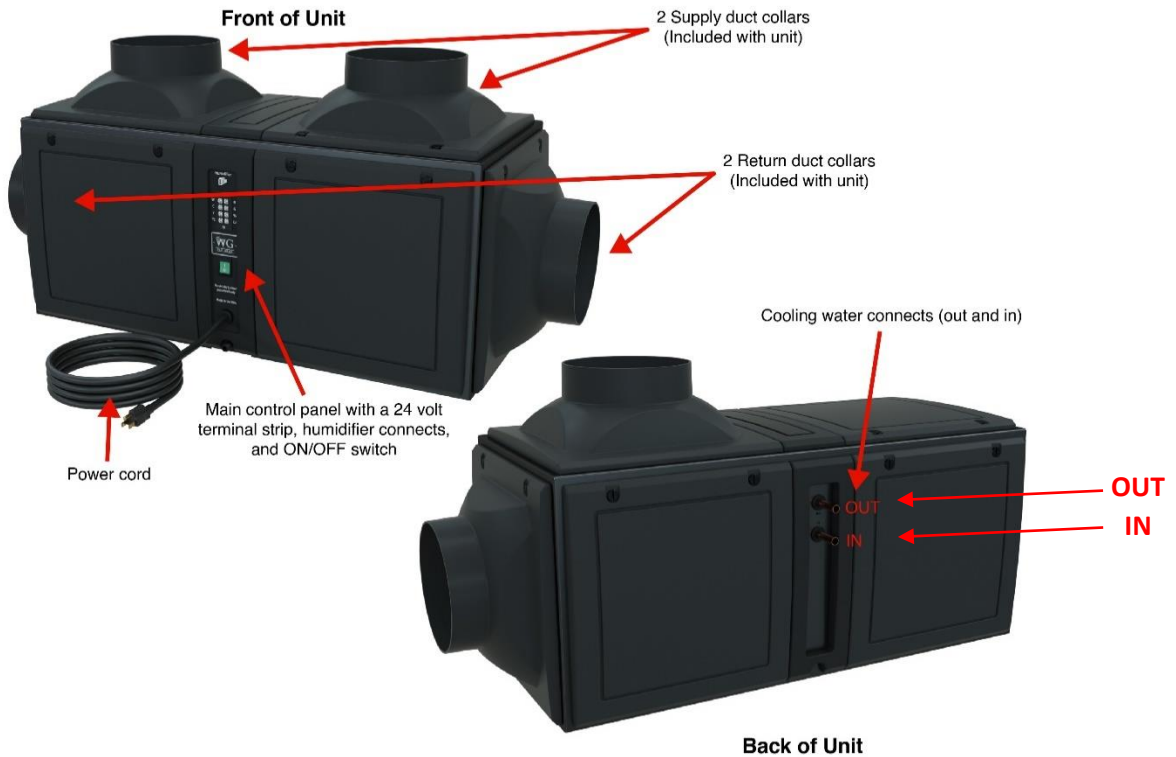
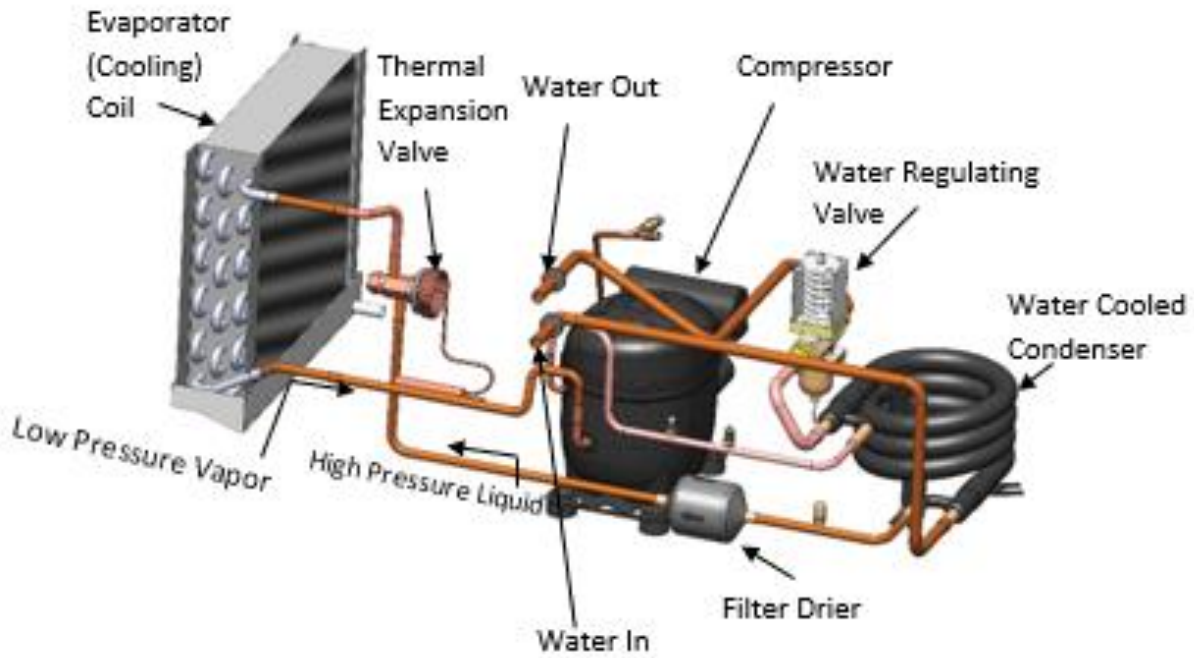
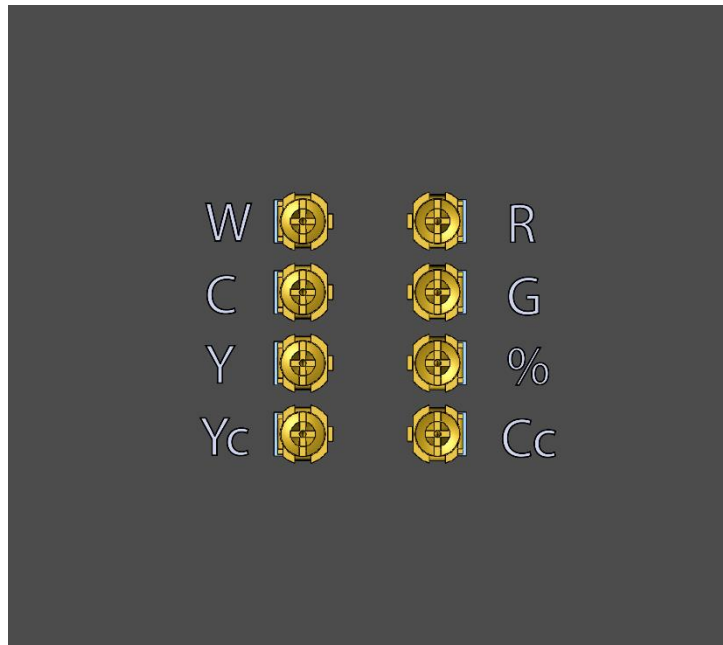

Fig. 4



**Terminal Strip**



White (W) = Heat

Cyan (C) = 24 Volt AC Common

Yellow (Y) = Cool

Red (R) = 24 Volt AC Power

Green (G) = Fan

% = Humidity Connection

Yc & Cc = Only used in Split Systems





Fig. 7 (DP88)

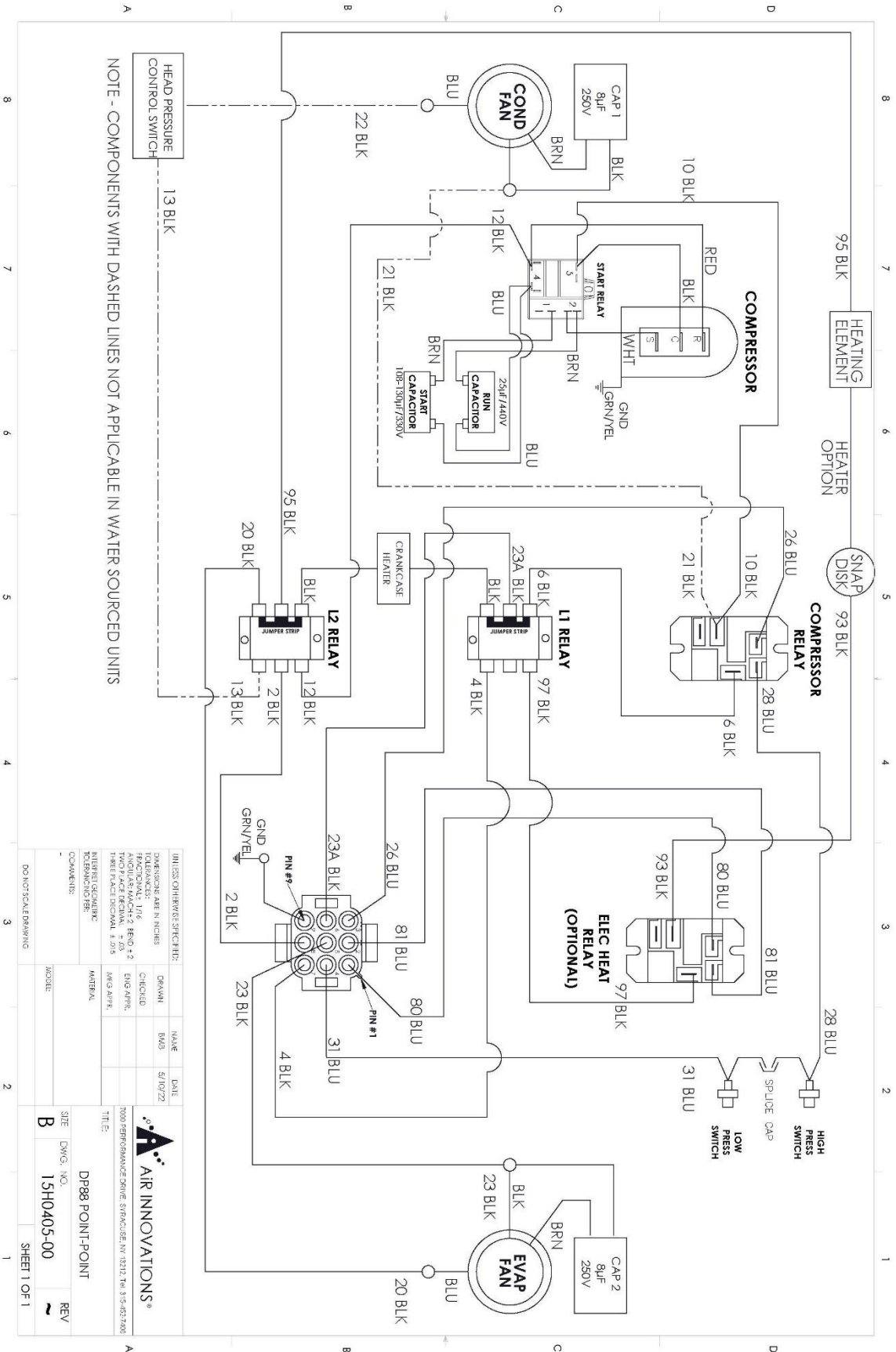

AIR INNOVATIONS®	
UNLESS OTHERWISE SPECIFIED:	
DIMENSIONS ARE IN INCHES	
TOLERANCES:	
FRACTIONS: 1/16	DECIMALS: .01
TWO PLACE DECIMAL: .05	THREE PLACE DECIMAL: .015
INTERFERING DIMENSIONS:	
TOLERANCING:	
COMMENTS:	
DATE:	5/10/22
NAME:	BMJ
CHECKED:	ENG APPR:
DRAWN:	ENG APPR:
DATE:	5/10/22
REV:	
DWG. NO.:	15H0405-00
SIZE:	B
TITLE:	DP88 POINT-POINT
7000 PERFORMANCE DRIVE SYRACUSE, NY 13212 TEL: 315-485-7400	
SHEET 1 OF 1	



Fig. 9 (DP200)

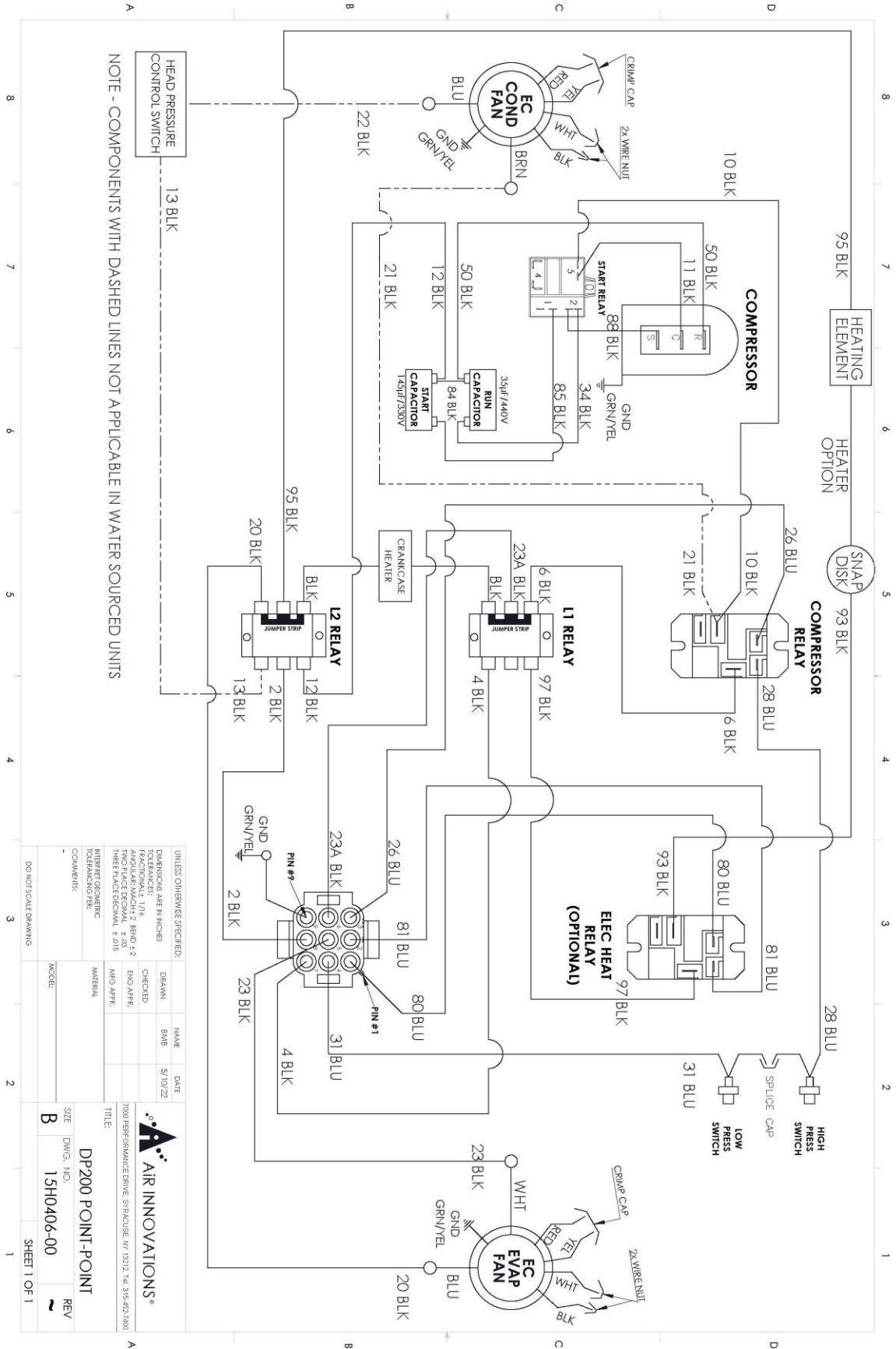

NOTE - COMPONENTS WITH DASHED LINES NOT APPLICABLE IN WATER SOURCED UNITS

UNLESS OTHERWISE SPECIFIED:		DRAWN		DATE	
DIMENSIONS ARE IN INCHES		BMB		5/10/22	
TOLERANCES:		CHECKED			
FRACTIONAL: 1/16		ENG APPR.			
DECIMAL: .005		MFG APPR.			
TWO PLACE DECIMAL: .05					
THREE PLACE DECIMAL: .015					
INTERPRETING PER:		MATERIAL			
TOLERANCING PER:					
COMMENTS:					
DO NOT SCALE DRAWING		TITLE:		REV	
		DP200 POINT-POINT		B	
		DWG. NO.		15H0406-00	
		SIZE		REV	
		B		~	
		SHEET 1 OF 1			

**AIR INNOVATIONS®**  
7000 PERFORMANCE DRIVE, SYRACUSE, NY 13210, TEL: 315-462-7400

Fig. 10 (DP200 Control Assembly)

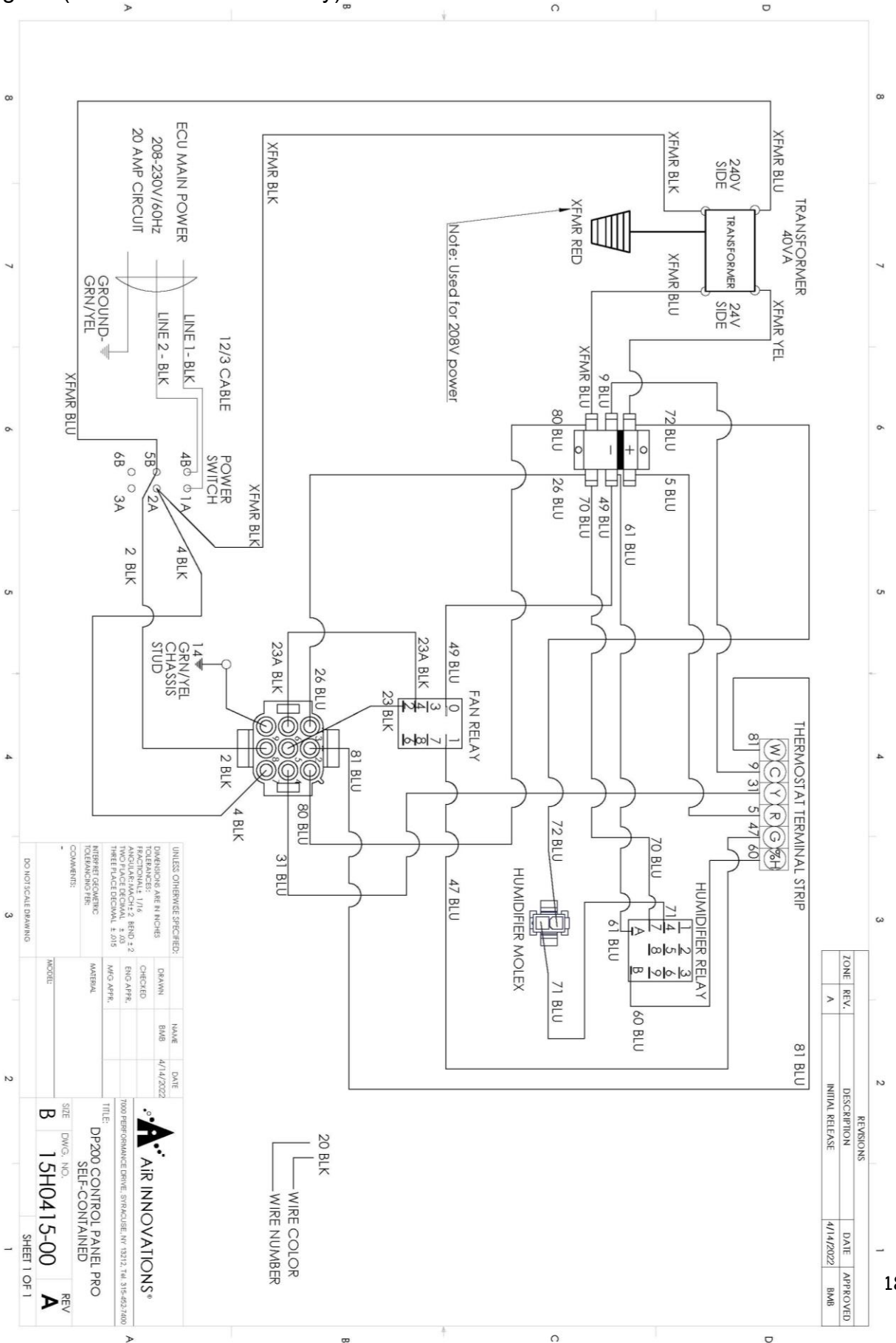

REVISIONS		DATE	APPROVED
ZONE	DESCRIPTION	4/14/2022	BMB
REV.	INITIAL RELEASE		
A			

UNLESS OTHERWISE SPECIFIED:		NAME	DATE
DIMENSIONS ARE IN INCHES	DRAWN	BMB	4/14/2022
FRACTIONAL: 1/16	CHECKED		
ANGULAR: MAX CH: 2 BRND: 2	ENG APPR.		
TWO PLACE DECIMAL: 2.00	MFG APPR.		
THREE PLACE DECIMAL: 2.015	MATERIAL		
RIBBET GEOMETRIC	COMMENTS:		
TECHNICAL FILE			
COMMENTS:			

1000 PERFORMANCE DRIVE, SPRINGFIELD, NY 12111, TEL: 315-452-1800	
TITLE: DP200 CONTROL PANEL PRO SELF-CONTAINED	
SIZE	DWG. NO.
B	15H0415-00
REV	REV
A	A

DO NOT SCALE DRAWING

20 BLK  
 WIRE COLOR  
 WIRE NUMBER

**Dimensions/Specifications**

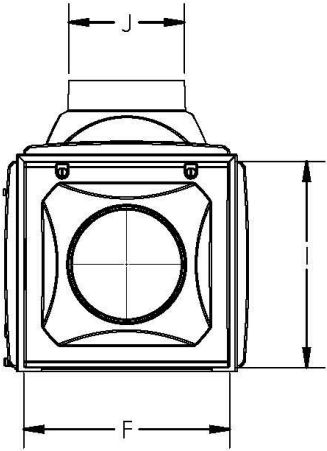
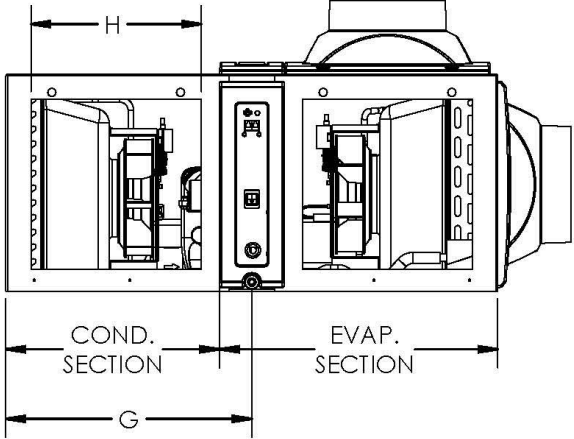
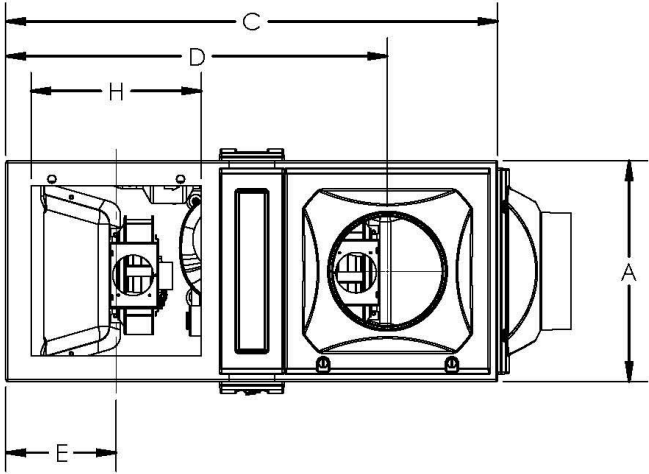

Dimensional Data for 60Hz Models

<b>Chassis Type</b>		<b>Chassis A</b>	<b>Chassis B</b>
<b>Model Number</b>		<b>DP25</b>	<b>DP50 / DP88 / DP200</b>
<b>Dimensions - Nominal - add 0.375 inches for each grille</b>			
A – Depth	Inches	16.6	22.4
B – Height	Inches	15.56	18.85
C – Width	Inches	33.45	41.5
D – Evap. discharge location	Inches	26.19	32
E – Cond. discharge location	Inches	7.26	10.33
F – Inlet opening width	Inches	14.52	15.55
G – Drain outlet location	Inches	16.73	20.75
H – Discharge opening width	Inches	14.52	14
I – Inlet opening Height	Inches	14.52	15.8
J – Duct opening	Inches	8	10
AA – Water out (O.D)	Inches	0.50	0.5
BB – Water in (O.D)	Inches	0.50	0.5
<b>Weight</b>	lbs.	80	125 / 125 / 206

# Specifications

## Wine Guardian Specification Sheet – 60Hz models

### SPECIFICATIONS Pro Ducted Cooling Units



### Sentinel Series

Model Number		DP25	DP50	DP88		DP200	
<b>Power Requirements</b>	volt/phase/hz	115/1/60	115/1/60	208/1/60	230/1/60	208/1/60	230/1/60
<b>Performance (57%/55%RH)</b>							
Nominal Compressor	HP	0.33	0.50	1	1	2.5	2.5
Net Cooling Capacity*		Total/Sensible	Total/Sensible	Total/Sensible	Total/Sensible	Total/Sensible	Total/Sensible
@60 Deg F condenser inlet air	BTUH	4520/3050	6920/4920	10700/7120	10830/7500	17570/12430	17680/12790
@70 Deg F condenser inlet air	BTUH	4300/2915	6570/4740	9900/6800	10250/7160	16590/11650	16720/12000
@80 Deg F condenser inlet air	BTUH	3760/2715	6320/4510	9420/6610	9600/6850	15350/11100	15680/11780
@90 Deg F condenser inlet air	BTUH	3540/2580	5860/4230	8600/6120	8760/6210	14000/10580	15000/10870
@110 Deg F condenser inlet air	BTUH	3260/2400	4863/3820	N/A	N/A	N/A	N/A
@120 Deg F condenser inlet air	BTUH	3000/2260	4585/3590	N/A	N/A	N/A	N/A
<b>Performance (80%/50%RH)</b>							
Nominal Compressor	HP	0.33	0.50	1	1	2.5	2.5
Net Cooling Capacity*		Total/Sensible	Total/Sensible	Total/Sensible	Total/Sensible	Total/Sensible	Total/Sensible
@60 Deg F condenser inlet air	BTUH	5980/4000	9830/6990	14330/9530	14560/10000	25450/18000	25600/18530
@70 Deg F condenser inlet air	BTUH	5570/3780	9250/6680	13690/9400	13860/9680	24250/17000	24460/17550
@80 Deg F condenser inlet air	BTUH	5080/3660	8720/6220	13000/9130	13140/9370	22440/16230	22930/17220
@90 Deg F condenser inlet air	BTUH	4425/3500	7835/5800	11800/8400	11300/8450	19500/15800	20500/15150
@110 Deg F condenser inlet air	BTUH	4070/3000	7140/5610	N/A	N/A	N/A	N/A
@120 Deg F condenser inlet air	BTUH	3780/2840	6690/5230	N/A	N/A	N/A	N/A
<b>Controls</b>							
Type		24 Volt Control - (Thermostat by Others)					
<b>Evaporator Section</b>							
Fan Motor Size	Watts	75	100	175	195	160	180
Rated Air Flow (free blow)	CFM	245	390	435	485	760	810
Rated Air Flow @ pressure loss	CFM	200 @0.10" wc	320 @0.20" wc	370 @0.20" wc	440 @0.20" wc	710 @0.35" wc	745 @0.35" wc
<b>Air-cooled Condenser Section</b>							
Fan Motor Size	Watts	75	100	175	195	160	180
Rated Air Flow (free blow)	CFM	245	390	435	485	760	810
Rated Air Flow @ pressure loss	CFM	200 @0.10" wc	320 @0.20" wc	370 @0.20" wc	440 @0.20" wc	700 @0.35" wc	725 @0.35" wc
<b>Water-cooled Condenser Section (option)</b>							
Water usage at 40 Deg F rise	GMP	0.30	0.60	1.20		2.50	
Pressure drop	PSI	0.40	0.40	0.08		1.20	
Pipe connection size (in/out) O.D.	Inches	0.50	0.50	0.50		0.50	
<b>Heat</b>							
Type		Electric					
Capacity	Watt/BTUH	1000/3400	1000/3400	1635/5582	2000/6800	1635/5582	2000/6800
<b>Humidifier (Option)</b>							
Type		Removable drip pad with integral fan					
Capacity - water temp of 60 Deg F	lbs./hr	0.42					
Capacity - water temp of 90 Deg F	lbs./hr	0.97					
Capacity - water temp of 100 Deg F	lbs./hr	1.11					
<b>Electrical Requirements</b>							
Current Draw - Cooling mode	Amps	7.1	11.3	9.8	8.8	15.6	14.1
Current Draw - Heating mode	Amps	9.4	9.6	8.8	9.5	8.8	9.5
Minimum Circuit amps (heat / no heat)	Amps	11.6/8.6	11.8/13.7	10.7/11.8	11.7/10.6	10.7/19.1	11.7/17.2
Optional Low Ambient	Amps	0.4	0.4	0.2	0.2	0.2	0.2
Optional High Ambient	Amps	0.2	0	N/A	N/A	N/A	N/A
Optional Humidifier	Amps	0.4	0.4	0.4	0.4	0.4	0.4
<b>Cabinet</b>							
Construction		Aluminum chassis & UL rated plastic panels					
Finish		Gray metal epoxy powder coat/textured PVC acylic blend					
Weight	lbs.	80	125	125		206	
Dimensions (inches)		33.45	41.5	41.5		41.5	
	Depth	16.6	22.4	22.4		22.4	
	Height	15.56	18.85	18.85		18.85	
Condensate Drain connection (ID)	inches	.50"	.50"	.50"		.50"	
Minimum Ductwork Size	Inches	8	10	10		12	
Agency Approvals	ETL	UL 1995/CSA C22.2					

1. Reduce capacity by 3% for each 10% reduction in evaporator airflow.
2. Wine Guardian reserves the right to make changes to this document without prior notice at its sole discretion.
3. All rating at sea level.

Wine Guardian Factory & Headquarters:  
7000 Performance Drive | North Syracuse, New York 13212 USA

Wine Guardian European Office:  
Pestalozzistrasse 2, CH-8201 Schaffhausen, Switzerland

help.wineguardian.com | info@wineguardian.com  
Wine Guardian® is a registered trademark of Air Innovations

## **Installation**

For questions or help regarding installation, call customer service at 1-315-452-7400 or email [info@wineguardian.com](mailto:info@wineguardian.com) a sketch of the proposed area where the unit is to be installed.

### **Pre-Installation**

Test the system before installing it to check for non-visible shipping damage.

- ✓ Set the system on the floor or a sturdy level surface.
- ✓ Plug in the system.
- ✓ Press the on/off switch and check that the control illuminates. This indicates the system has power.
- ✓ The built-in timer prevents short cycling and keeps the system from turning on right away.



**RISK OF PERSONAL INJURY OR DAMAGE TO EQUIPMENT  
SHARP EDGES ARE PRESENT INSIDE THE WINE GUARDIAN SYSTEM**

### **Replacing a Pre 2020 Legacy Series Unit**

It is important to note our dimensional differences between our current production Sentinel series units (manufactured post 2020) and our Legacy series units (manufactured pre 2020) have dimensional differences for those who are replacing our older production models. The table below will assist in ensuring there is enough space in the installation location to be appropriate on the current units.

<b>Self Contained System Size Differences</b>				
	<b>DP25</b>	<b>DP50</b>	<b>DP88</b>	<b>DP200</b>
<b>L (in)</b>	1.33	14.39	14.39	-7.48
<b>W (in)</b>	2.6	2	2	1.62
<b>H (in)</b>	0.76	4.85	4.85	0.85

### **Pre-Installation Planning**

Prior to installation determine how best to mount the unit.

Floor Mounting - Mount the Wine Guardian fan coil on the floor but elevate it 4" (10cm) as a minimum on a frame with a plywood surface to keep it away from water. Allow adequate space for the external drain.

Fig. 1

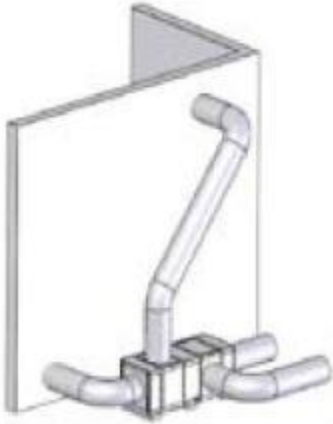

Wall Mounting - If the unit is to be surface mounted on the wall, adequately support it on both sides of the wall. Use floor or knee braces to transfer the load of the unit to the floor or wall.

Fig. 2

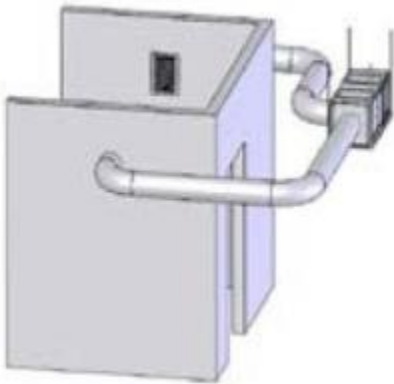

Ceiling Mounting - Construct a structurally sound, level platform to place the unit on when hanging it from the ceiling joists. The Wine Guardian system is NOT designed to be suspended from the top of the unit; it must be supported from the bottom. Place the unit on a platform to ensure that the unit is supported on all four corners. Leave adequate space on the top of the unit to remove the access doors for service.

In all cases, the unit must be level to within  $\pm 0.25"$  ( $\pm 6.35\text{mm}$ ) end-to-end and  $\pm 1/8"$  ( $\pm 3.18\text{mm}$ ) side-to-side for proper operation. Locate the unit as close to the wine cellar as possible to reduce the length of the duct runs. If possible, use straight ducting on all ductwork.

### **Reducing Noise Generation**

Consider noise when locating the unit close to the cellar or to an adjacent occupied space. The addition of 0.25in-thick (6.35mm-thick) rubber pads help prevent the transmission of vibration and noise. A piece of 1" or 2" (25 or 50mm) noise dampener between the unit and the wall absorbs and reduces the noise from the unit. For air noise reduction, use flexible ductwork to absorb the noise. Sound usually travels as a line of sight. Sound is reduced when it turns a corner, such as passing through a bend in ductwork. If the unit is supported from a wall or joist, using a rubber pad under the unit will reduce vibration transmission.

## Ductwork

Wine Guardian units are typically installed indoors near the wine cellar to minimize the duct runs. Each unit is provided with one entering or return air inlet and three possible supply air outlets for each of the evaporator and condenser sections. A maximum cumulative total length for both supply and return ducts (including bends) of 25ft (7.5m) is recommended. If longer runs are needed, examine your duct run using our [Ductwork Calculator](#)

Use ductwork to connect the unit to the supply and return outlets in the wine cellar. Use only insulated ductwork to minimize cooling losses, prevent sweating, and to reduce noise.

Use ductwork on the condenser section to redirect or absorb sound, to bring in outside air to the unit inlet, and/or to exhaust the hot air out of the ambient space.

Ductwork Diameters (inches) – Wine Guardian 60 Hz units		
Model #	Evaporator (cold air side) Condenser (hot air side)	
	Single Duct Run	Double Duct Run
DP25	8	6
DP50/DP88	10	8
DP200	12	10

It is best to oversize ductwork if exact ductwork diameters are not readily available or easily accessible

**Note:** The above-referenced sizes are internal diameter in inches for 60Hz and in millimeters for 50Hz. If a single supply duct is used but then splits into two ducts, the duct size that is recommended for double duct runs is used after the split occurs (ex. 8" duct would split into two 6" ducts).

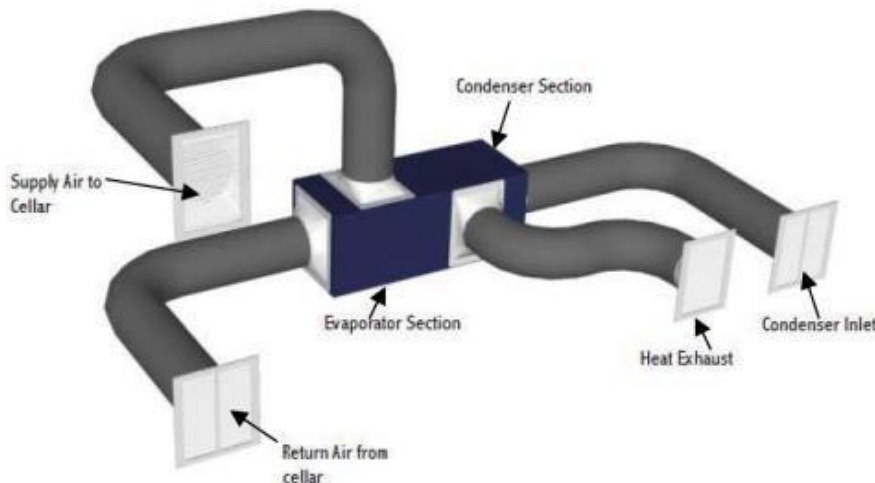

**Note:** Uninsulated ducts and surfaces cause base exposed metal to sweat which can cause a degradation of insulation, a loss of cooling capacity, and in some cases lead to water damage.

**Note:** If the cooling unit is placed in a hot and humid location it could form condensation on the chassis. To help reduce the chances of this happening the unit should be wrapped in insulation and placed inside a secondary drip pan.

## **Duct Collar and Panel Adjustment**



Fig. 1



Fig. 2



Fig. 3



Fig. 4



Fig. 5

To replace or adjust the locations of the panels and Supply Collar please see the instructions below:

1. Determine which panel needs to be replaced (Fig 1).
2. Use a flat blade screwdriver, coin, or other suitable tool at the captive fastener (Fig 2).
3. Apply a simple quarter turn counterclockwise to allow the fastener to disengage from the housing (Fig 3).
4. Remove the panel by sliding the panel/collar up to disengage the bottom hook from the housing before completely removing the panel/collar from the unit (Fig 4).
5. To replace the panel/collar, simply reverse the previous steps. Press the panel against the opening and slide it down to connect the bottom hook of the panel/collar to the housing (Fig 5). Push the top of the panel in and line up the fasteners with holes in the housing. Insert the tool into the fastener and quarter turn clockwise to lock into place.

## Drain Line

Splice the drain line onto the drain outlet with a short piece of ½” copper tubing and secure the drain line to the unit with a hose clamp. The Drain Line’s interior diameter should be ½”. The drain line must extend from the unit to an open floor drain or condensate pump. Do **NOT** install an external trap on the drain line, ever ducted wine guardian unit is built with an internal trap. Allow enough height for the drain line to function properly. If draining into a nearby sink, the unit must be elevated higher than the rim of the sink in order for the water to drain by gravity. Install with a ¼” per linear foot of pitch. **Do not** tie the condensate drain line directly into the sanitary sewer system. The internal drain trap primes itself automatically once the unit has run for a period of time and after the unit cycles off. This is confirmed by water dripping from the drain.

## Wiring to Power

Match the Electrical Wiring to the cord provided on the Wine Guardian. Provide dedicated circuit and wiring for the system. Match the wiring and breaker size to the rated load as shown on the serial plate and in this guide. Please see the sample serial plate illustration.

	
<b>MODEL: DP25</b>	
<b>P/N : 99H0200-20</b>	
<b>S/N : XX-XX-XXX</b>	
<b>REV : A</b>	
Refrigerant	R-134A
System Charge	19 oz
Test Pressure	275 psi
Electrical	115/1/60
Min. Circuit amps	8.9
Compressor RLA	5.82
Locked Rotor Amps	32
Condenser Fan Amps	0.8
Evaporator Fan Amps	0.8
Humidifier Amps	0.3
Crankcase Heat Amps	0.4
Total Unit Amps	7.4



**ELECTRICAL SHOCK HAZARD  
RISK OF SERIOUS INJURY OR DEATH**  
**The electrical outlet and wiring installation must  
meet the  
national and local building codes.**



Conforms to UL STD 1985  
Certified to CAN/CSA STD C22.2 NO. 236

 **AiR INNOVATIONS**  
7000 Performance Dr.  
North Syracuse, New York USA 13212  
[help.wineguardian.com](http://help.wineguardian.com)

**S/N : XX-XX-XXX**  
**MODEL: DP25**  
**[help.wineguardian.com](http://help.wineguardian.com)**

Do **NOT** modify the plugs in any way. Do **NOT** use extension cords.

Depending on the model the electrical power supply must be either 115-volt or 230-volt AC, 1 phase, 60 cycle, the electrical power cannot vary more than plus or minus 4% or damage may occur to the unit.

Plug the unit into the wall outlet, gently pull on the plug to make sure it is tight.

Fig. 1: Plug configurations

Required For:  
Models DP25

-115VAC, 60Hz

-NEMA 5-15R

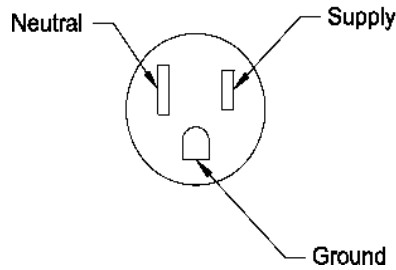

Required For:  
Models D088

-230VAC, 60Hz

-NEMA 6-15P

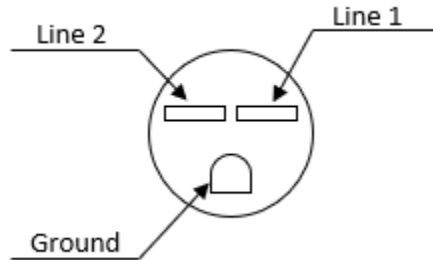

Required For:  
Models D200

-230VAC, 60Hz

-NEMA 6-20P

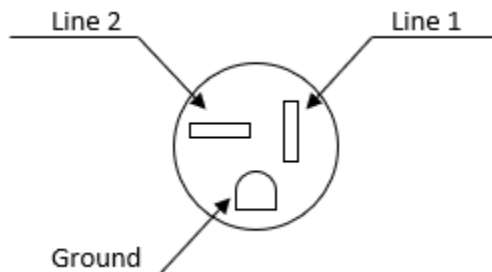

## **Start-Up**

- Check over the installation and ensure all wiring connections are correct
- Examine all duct connections, grilles, and panels in case any are not connected
- Start the unit
- Check ducts and duct connections for any possible air leaks
- Confirm condenser airflow is unrestricted

Now that the installation is complete plug in the unit. Turn-on the on/off switch on the side of the unit. The on/off switch lights up to indicate power to the unit. The unit may not turn on right away due to the timer built into the circuiting to prevent compressor short cycling. The fan will only run when the system has a call for cooling which will occur when the wine room's temperature is above the setpoint. Once the unit begins cooling wait the allotted 5 minutes for the compressor to run. To check if the compressor is running, check if cool air is leaving the evaporator or if you can hear a humming noise from the compressor itself.

During the initial start-up, the unit may run continuously for several hours, up to a day or more, while it lowers the cellar temperature. Once the unit reaches the set point temperature, it shuts off and starts to cycle on and off as it continues to lower the bottle temperature to the set point. The cellar air reaches the set point before the bottles. If the cellar temperature started at 75 °F (24 °C), the supply air temperature discharged from the unit will probably be 15 °F to 20 °F (-4 to -7 °C) colder. As the cellar temperature decreases to 55 °F (13 °C), the supply temperature differential decreases 8 to 12 °F (4.4 to 6.7°C) colder.

To decrease the run-time of the unit it is recommended to use a step down process. For example, if you are aiming to hit a 55 degrees F setpoint then you would set an initial set point of 63 degrees F. Once the system has reached 63 degrees F change the set point to 60 degrees F, then 55 degrees F. Drop the setpoint in increments, so the system has time to cycle instead of running continuously to reach the preferred set point.

## Maintenance



Risk of Serious Injury or Death  
Use Lockout/Tagout Procedure before opening panels

### Sharp Edges

Risk of Serious Injury  
Sharp Edges are present on the fan wheels, housing, fins, and coils

Maintenance on Wine Guardian units requires working with high voltage and sheet metal with possible sharp edges. Only qualified personnel should perform maintenance. Some tasks require knowledge of mechanical and electrical methods. Make sure you are familiar with all hazards, general safety related procedures, and safety labels on the unit.

Standing water in drain pans promote microbial growth (mold) that cause unpleasant odors and serious health-related indoor air quality problems. If mold is found, remove it immediately and sanitize that portion of the unit.

The Wine Guardian is designed for minimal maintenance. The refrigerant system is hermetically sealed and requires no maintenance. The fans are permanently lubricated and require no maintenance. Some maintenance to the unit may be required due to dust or dirt in the air stream.

The condenser coil is provided with a reusable, washable air filter. The filter protects the coil from becoming coated or plugged by dust. Frequency of cleaning the filters is based on the amount of dust or dirt generated in the cellar or basement.

1. Remove the duct collar on the inlet end of the unit. (Optional)
2. Remove the filter covering the face the coil.
3. Wash it under warm water.
4. Shake off excess water.
5. Inspect and clean the face of the coil. **Sharp edges are present on the fins and coils.**
6. Reinstall the filter.
7. Replace the duct collar.

The condensate drain system traps dust and dirt. Clean the drain system once a year.

1. Shut off the rocker switch and unplug the unit.
2. Remove the grille or duct on the evaporator inlet.
3. Remove the filter and inspect the drain pan under the coil.
4. If drain pan appears soiled, pour some hot water mixed with liquid bleach (diluted solution) along the length of the pan to flush the dirt down the drain tube. Continue this treatment until the drain appears clean and free of dirt.
5. Reinstall filter and grille/duct collar.
6. Plug in the unit and restart.

## **Flushing the Water Regulating Valve – Water-Cooled Only**

To clear any sediment that may accumulate, valves may be manually flushed by inserting screwdrivers under both sides of the main spring and lifting upwards to flush the valve. Manual flushing does not affect valve adjustments.

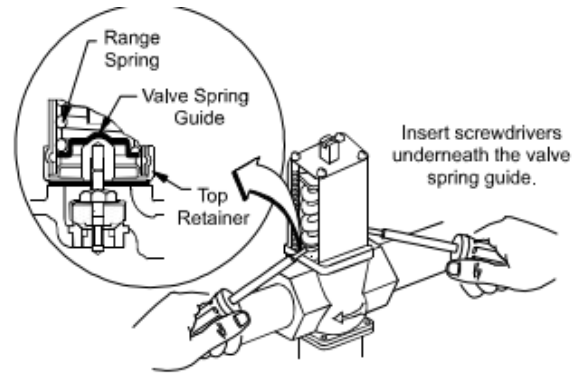

## **Cleaning the Humidifier (Optional)**

If the unit was furnished with a humidifier, it requires periodic maintenance. Follow the instructions in the humidifier guide.

## **Maintenance Schedule**

### **Monthly**

(or quarterly depending on experience with cellar)

- Check filter and drain trap – clean if needed.
- Check for noise or vibration.
- Check for short-cycling of the unit – a turning on and off of the compressor unit more than eight times/hour.

### **Yearly**

(in addition to monthly)

- Replace filters if worn or plugged beyond cleaning.
- Check evaporator and condenser coils for dirt – use a vacuum with a brush attachment to clean the coils.
- Clean condensate pan under the evaporator coil by flushing. Be careful to keep the drains pans clear of all debris.
- Inspect cabinet for corrosion or rusting – clean and paint.
- Inspect for dirt buildup on or inside the unit. Clean unit by vacuuming or wiping it down.
- Check for loose insulation, fasteners, gaskets, or connections.
- Check the wiring connections and integrity of cords.
- Examine ducts for any cracks or breach.
- Check fan and solenoid on humidifier.
- Replace humidifier drip pad (if applicable)

## **Troubleshooting**

**Before proceeding, read and understand the safety information contained in the Safety Section of the Wine Guardian Manual**

For in-depth Troubleshooting please head to:

[Help.wineguardian.com](http://Help.wineguardian.com)

### **Resetting the High-Pressure Switch**

High-Pressure Switch Has Shut Down the Unit	
Every Wine Guardian unit has a manual reset high pressure switch in the refrigeration system. This switch shuts the compressor and condenser down if the head pressure in the system is too high. It is intended to protect the compressor. Restricted airflow through the condenser is the most common reason for the pressure to become too high. This can be caused by dust covering the filter or an obstruction blocking the airflow in the duct or grille.	
Possible Cause	Solution
Head Pressure in unit is too high because an obstruction is restricting airflow	Remove the obstruction in the duct/grille or clean the filter. Then restart the unit after resetting the high-pressure switch

1. Shut off the unit at the power switch, Remove the access panel, grille, or duct collar on the condenser to gain access to the High-Pressure Switch.
2. Locate the High-Pressure Switch near the compressor (Fig. 1).
3. Push the button to reset the High-Pressure Switch.
4. Push the power switch to restart the unit.



Fig. 1

Please see the link below for a video on how to reset the High-Pressure Switch  
<https://www.youtube.com/watch?v=TFGFTWZVeAs>

## **Contact and Warranty**

### **GENERAL**

Wine Guardian warrants, to the original buyer, its goods, and all parts thereof to be free from defects in material and workmanship for a period of two (2) years from the date of invoicing assuming NORMAL USE AND SERVICE.

### **LIABILITY**

Wine Guardian liability shall be limited to the repair or replacement (at its option) of any part, which, at our sole discretion, is determined to be defective. The purchaser shall pay all transportation costs. Additionally, if a malfunction occurs within the first year from the date of invoice, Wine Guardian will reimburse the reasonable cost of labor required for the repair or replacement provided authorization is obtained from one of our authorized representatives prior to incurring any labor charges.

### **LIMITATIONS OF LIABILITY**

THESE WARRANTIES ARE MADE IN LIEU OF ALL OTHER WARRANTIES EXPRESSED OR IMPLIED, INCLUDING ANY IMPLIED WARRANTY OF MERCHANTABILITY OR FITNESS FOR A PARTICULAR PURPOSE AND IN LIEU OF ANY OTHER OBLIGATION OR LIABILITY, INCLUDING LIABILITY FOR ANY INCIDENTAL OR CONSEQUENTIAL DAMAGES. Wine Guardian will not be responsible for any costs or liabilities whatsoever resulting from improper installation or service of its equipment. In the event that Wine Guardian or its distributors are found liable for damage based on any defect or nonconformity in the products, their total liability for each defective product shall not exceed the purchase price of such defective products. No person or representative is authorized to change these warranties or assume any other obligations or liabilities for Wine Guardian in connection with the sale of its systems.

### **INDEMNIFICATION**

Purchaser agrees to indemnify, hold harmless and defend seller and its officers, directors, agents, and employees from and against any and all claims, liabilities, costs and expenses arising out of or related to Purchaser's use of the goods, or in any way involving injury to person or property or accident occasioned by the goods sold by Wine Guardian to Purchaser.

### **FOREIGN GOVERNMENT AND INDIAN NATIONS**

If Purchaser is a foreign government or an Indian nation, Purchaser hereby expressly waives its defense of sovereign immunity in the event of a dispute between Purchaser and Wine Guardian regarding this invoice and Purchaser expressly acquiesces to the jurisdiction of the federal and state courts of the United States.

### **SEVERABILITY**

If one or more of the provisions contained in this contract shall for any reason be held to be invalid, illegal, or unenforceable in any respect, such invalidity, illegality, or unenforceability shall not affect any provision of this contract, but this contract shall be

construed as if such invalid, illegal or unenforceable provision had never been contained.

### **ADDITIONAL REQUIREMENTS**

If a defect covered by the Warranty occurs, contact Wine Guardian for authorization to proceed with corrective action. Do not return any parts or incur any charges for which you expect to be reimbursed under this Warranty without receiving this authorization. If parts are replaced under this Warranty, the defective parts must be returned prepaid within 30 days. This warranty shall be null and void in its entirety if the Serial Number on the air conditioner or compressor is altered, removed, or defaced.

### **Contact Information**

Wine Guardian  
7000 Performance Drive  
North Syracuse, NY, 13212

Web sites: [wineguardian.com](http://wineguardian.com)  
[Help.wineguardian.com](http://Help.wineguardian.com)

Email: [info@wineguardian.com](mailto:info@wineguardian.com)

### **Warranty**

The Wine Guardian unit serial number is noted on all packing lists and bills of lading and, along with shipping date, is kept on file at Wine Guardian for warranty purposes.

**All correspondence regarding warranty must include the model number and serial number of the unit involved.** **Note** that the warranty is null and void if the serial number on the unit or compressor is altered, removed, or defaced. All Inquiries or correspondence regarding warranty should be handled in accordance with the "Warranty" and directed to:

**Wine Guardian**  
7000 Performance Drive  
North Syracuse, New York, 13212  
Attn: Service Department

This procedure includes but is not limited to

- Obtaining authorization from Wine Guardian prior to incurring any charges for repair or replacement under warranty.
- Or returning prepaid within 30 days any and all defective parts.